

Maßstab ( 1 : 1 )

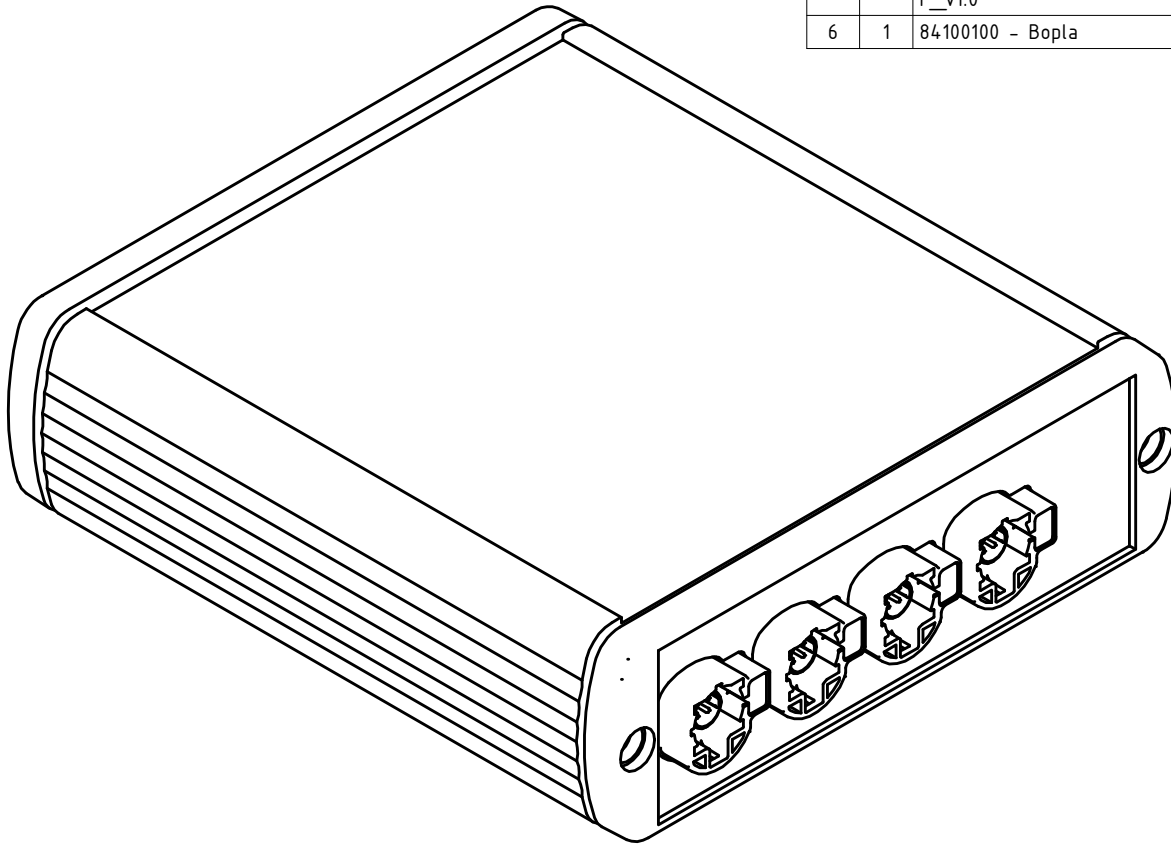

Stückliste

Pos.	Stck.	Bauteilnummer	Rev.	Bezeichnung	BestandsNr.	ZULIEFERER
2	1	ATS-CZ-0289-10	0	Rueckplatte_ABB1000-2		Bopla
3	1	ATS-GE-0901-10	0	Rueckplatte_ABB1000-2		Bopla
4	1	PCB3D_GPatch6222_Var8_2L2I_2L2O_P_v1.0	0	GPatch6222_2L2I_2L2O_P_v1.0		
6	1	84100100 - Bopla	0	ABP 1000-0100		Bopla

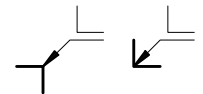

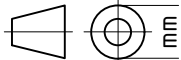

Allg.Toleranzen DIN ISO 2768 - m K      Masse 0,14 kg      Abmaße 121,9 x 32 x 106

Material	Konstruktion IG 12.12.2019	 ATS-E Projekt / Erstverwendung
Halbzeug	Zeichnung CZ 02.03.2021	
Oberfläche	Prüfung CZ 15.06.2022	 Format A4
	Status Freigegeben	

REV.	ÄNDERUNGSTEXT	DATUM	FREIGABE

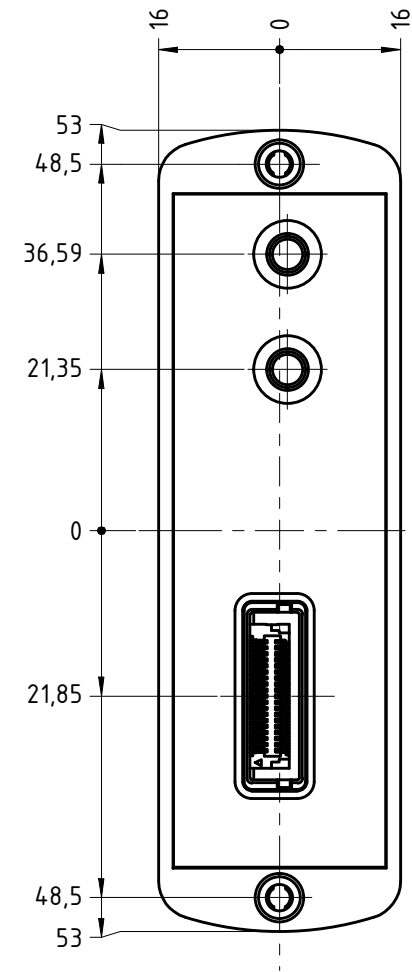
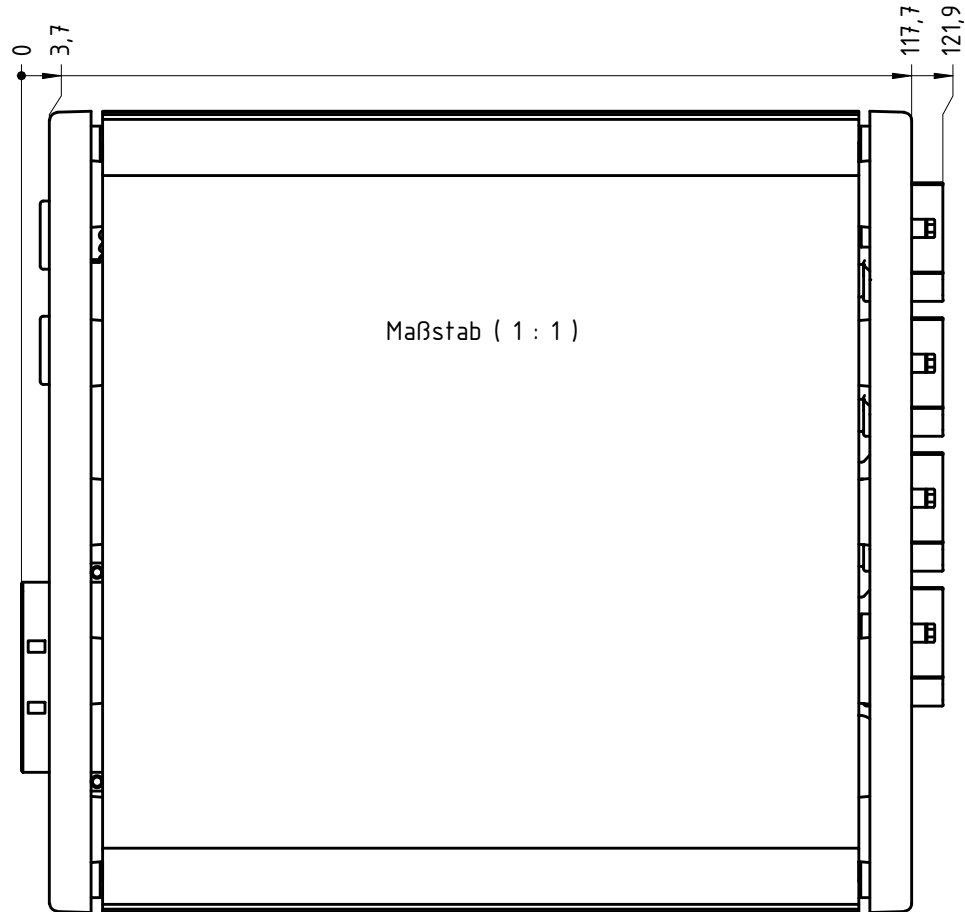
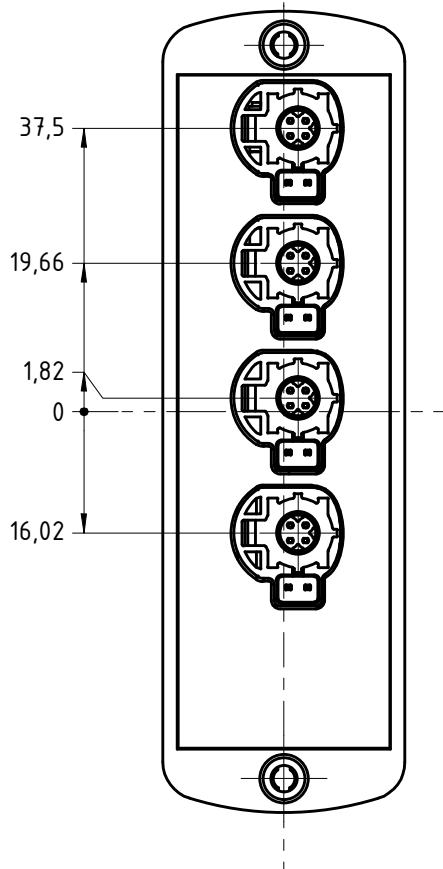
Bezeichnung <b>PCB3D_GPatch6222_1L2I_1L10_P_TypA_v1.0</b>	Zeichnungsnummer - Revision <b>ATS-CZ-0105-11-0</b>	Bestandsnummer	Blatt 1 / 2
--	--	----------------	----------------

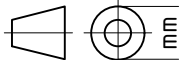

Allg.Toleranzen DIN ISO 2768 - m K		Masse 0,14 kg	Abmaße 121,9 x 32 x 106	
Material	IG	12.12.2019	 <b>GOPEL electronic</b>	
Halbzeug	CZ	02.03.2021		
Oberfläche	CZ	15.06.2022	Projekt / Erstverwendung	
Bezeichnung	Freigegeben			Format A4
PCB3D_GPatch6222_1L2I_1L10_P_TypA_v1.0		Zeichnungsnummer - Revision ATS-CZ-0105-11-0		Blatt 2 / 2